



Improving Equipment Reliability with Real-time Data

Williston Basin Petroleum Conference – May 2011



Reliability Staircase

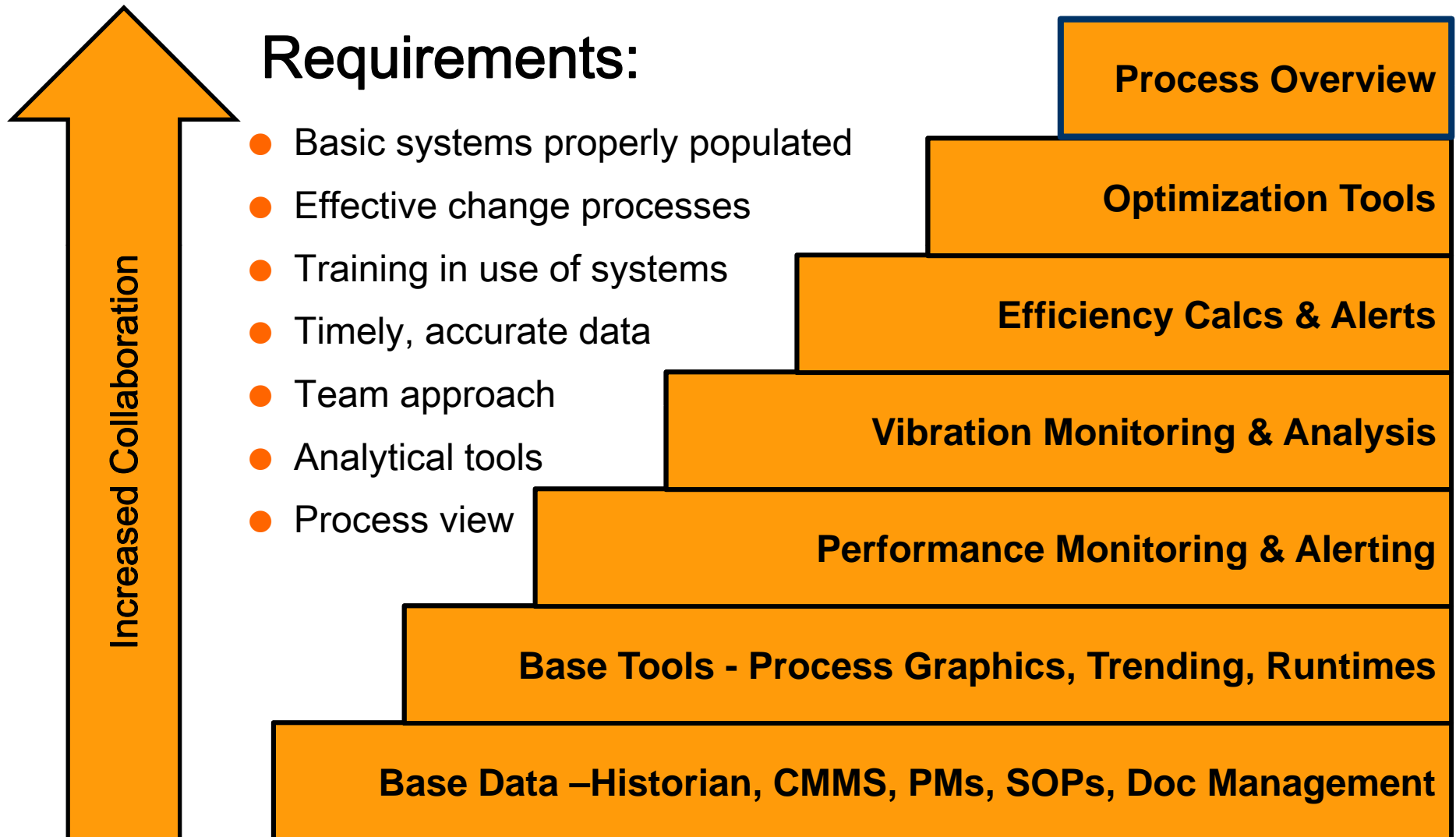



Real-time Data - Alerting versus Alarms

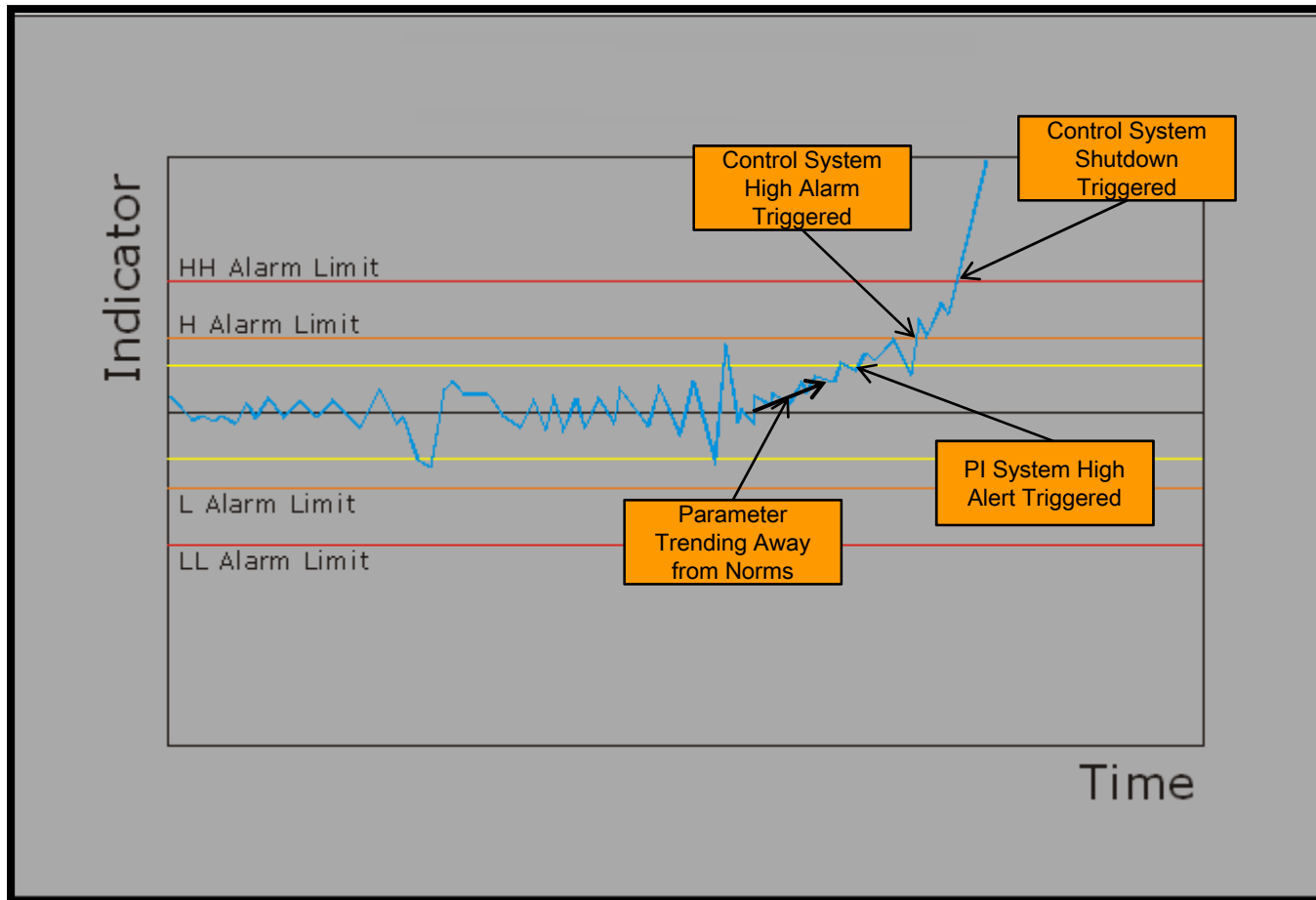



Pump Example

Pump Process Graphic

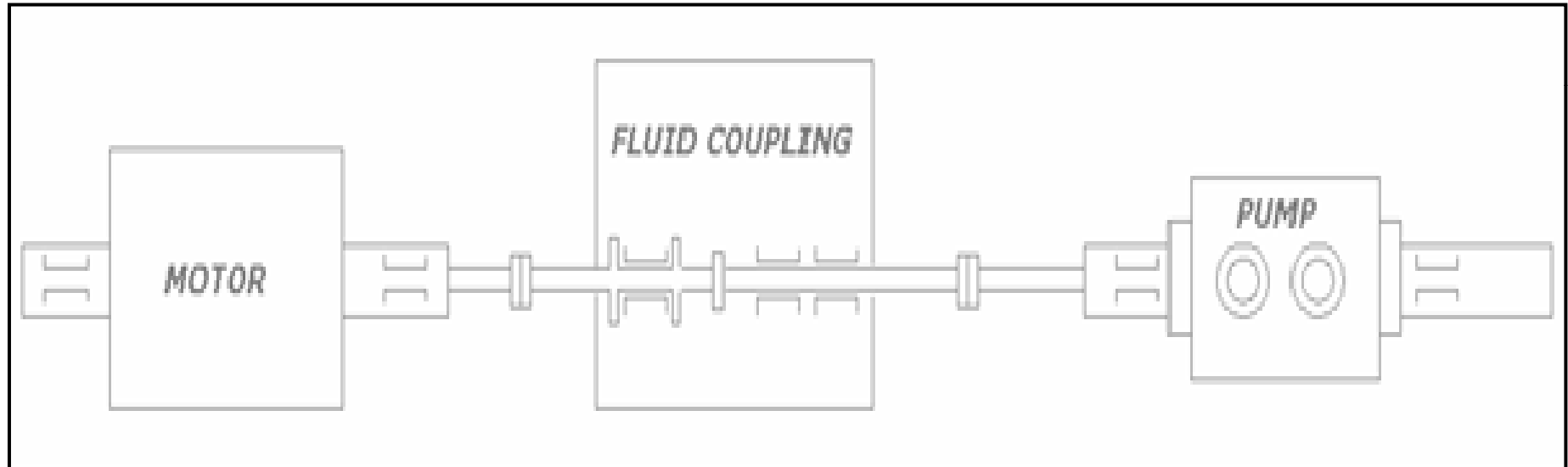

A pump is made up of a motor, coupling & pump unit, but referred to as a “**Pump**”



Pump Data Sheet

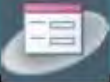

Reciprocating Pump Characteristics

Equipment Number:	1545678	Body Type:	Split Case
Corresponding Driver:	PM-1001	Shaft Orientation:	Horizontal
Drive Equipment Number:	1548546	Shaft Sealing:	Mechanical
Type of Driver:	Electric Motor	Transmission Type:	Direct-drive
Fluid Handled:	Methanol	Coupling:	Fixed
Power (Design):	15 KW	Pump Cooling:	No
Suction Pressure (Design):	2 kPa	Radial Bearing:	Journal
Discharge Pressure (Design):	1.5 Mpa	Thrust Bearing:	Journal
Speed (Design):	1800 RPM	Bearing Support:	Pump Casing
Number of Stages:	2		



Pump Process Graphic

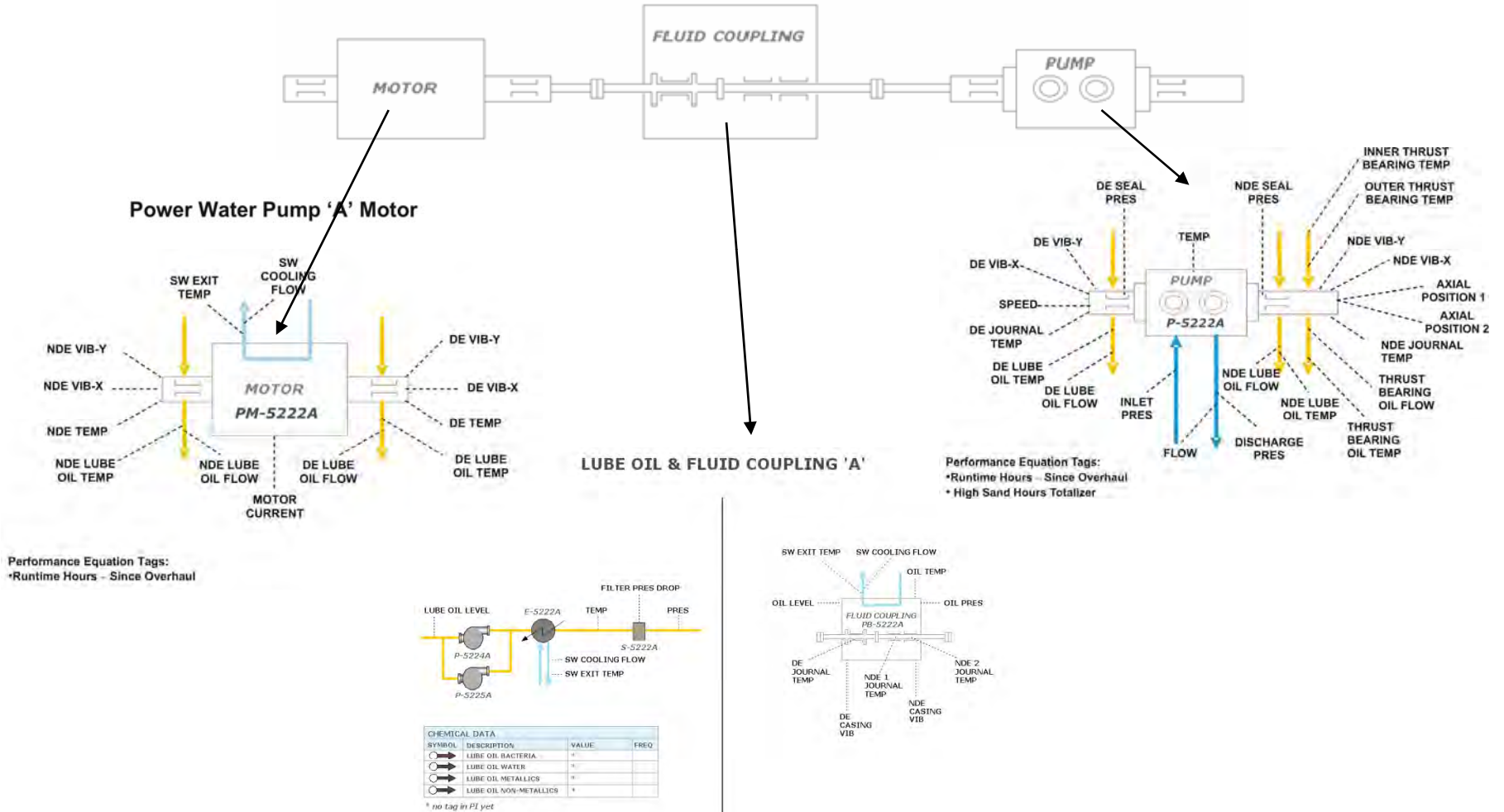



Single Speed Pump Analysis



Tag	Description	Units	10 Minute Average	10 Minute Average Head (m)	User Defined Average	User Defined Average Head (m)
CAP-50_FI_3001.NIV	P-5020 Flow Rate	m3/h	690.0	110.38	680.4385798	110.21
CAP-50_PT_3016.PV	P-5020 Discharge Pressure	Barg	8.665		8.647	



Variable Speed Pump Analysis

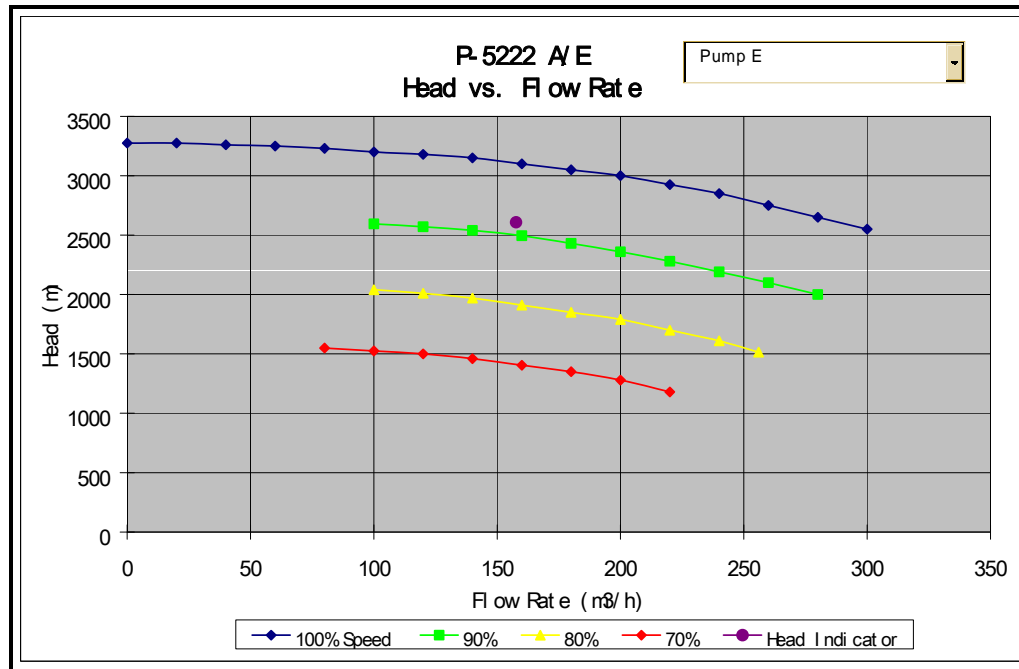

Time Interval	
Start (dd-mmm-yy hh:mm:ss)	01-Jul-08 12:00:00
End (dd-mmm-yy hh:mm:ss)	01-Jul-08 12:10:00
Interval	00:10:00

Assumptions	
g =	9.81 m/s ²
ρ =	1017 kg/m ³

Tag	Description	Units	Value	Head (m)
CAP-52_PI_8504.PV	Suction Pressure	barg	11.914	
CAP-52_PI_8506.PV	Discharge Pressure	BARG	272.102	
CAP-52_FI_8508.PV	Flow Rate	m ³ /hr	157.698	2,607.9
CAP-52_SI_8600.PV	Pump Speed	RPM	3428.2	
CAP-52_SI_8600.PV	Speed Percentage	%	98.0	



Performance over Time Analysis

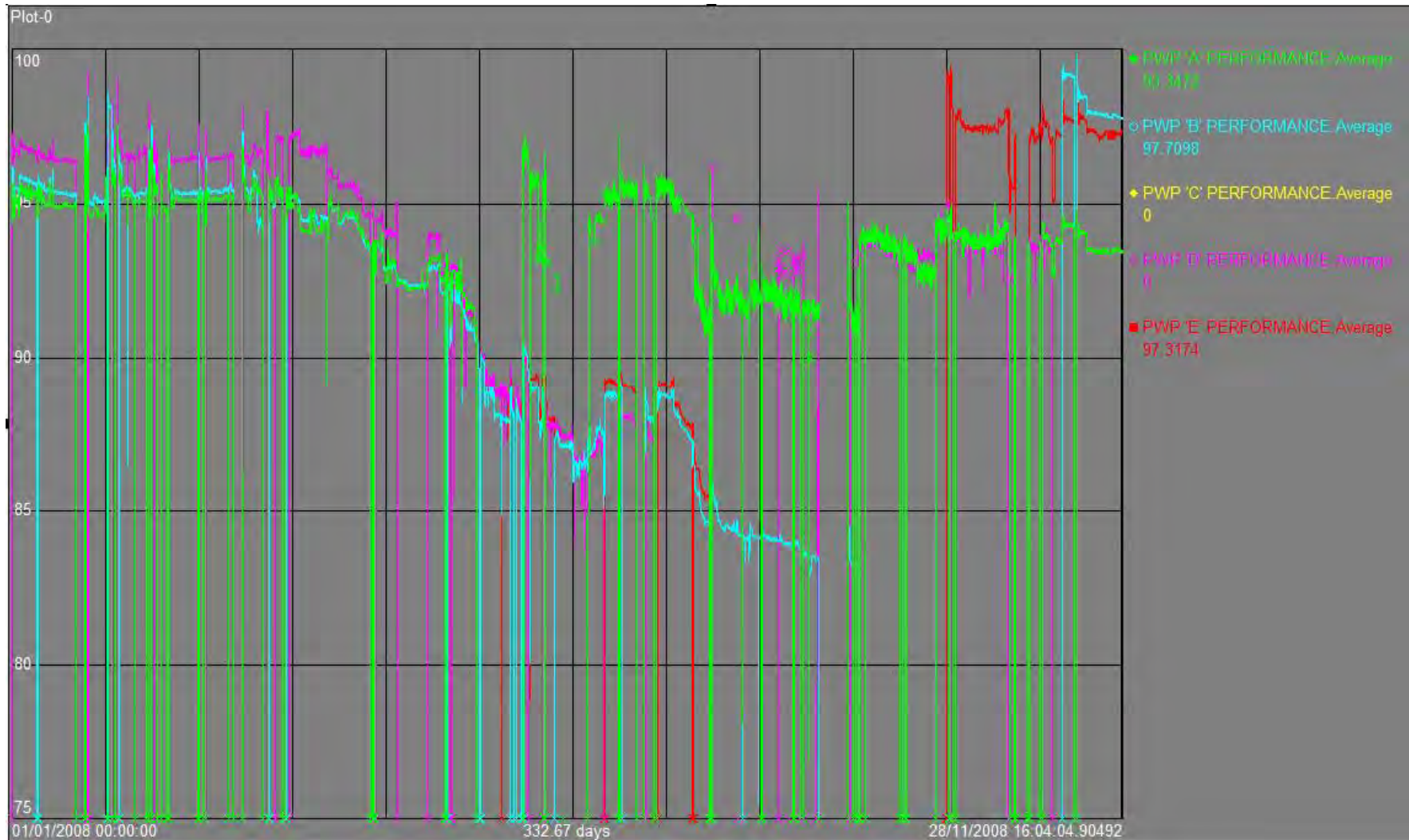



Pump Condition Overview

POWER WATER SUPPLY PUMPS A-E OVERVIEW

Update Display

PUMPS

	A	B	C	D	E
RUNNING	●	●	●	●	●
PERFORMANCE	●	●	●	●	●
MOTOR	●	●	●	●	●
FLUID COUPLING	●	●	●	●	●
IMPELLER	●	●	●	●	●

RUNNING
PERFORMANCE
MOTOR
FLUID COUPLING
IMPELLER



Efficiency Improvements

Well CO2 Production

Well 1 Well CO2	Well 2 Well CO2	Well 3 Well CO2	Well 4 Well CO2
Flowrate 18.9 e³m³/d	Flowrate 21.7 e³m³/d	Flowrate 46.6 e³m³/d	Flowrate 12.6 e³m³/d
CO2 Fraction 0.03 molFrac	CO2 Fraction 0.02 molFrac	CO2 Fraction 0.03 molFrac	CO2 Fraction 0.02 molFrac
CO2 Production 1.1 Tonnes/d	CO2 Production 0.7 Tonnes/d	CO2 Production 2.6 Tonnes/d	CO2 Production 0.4 Tonnes/d

Site Fuel Gas Consumption

Compressor 1 Engine	Sour 1 Line Heater	Sour 2 Line Heater	Site Sweet Reboiler	Site Sour Reboiler
C1 0.87	C1 0.87	C1 0.87	C1 0.87	C1 0.87
C2 0.07	C2 0.07	C2 0.07	C2 0.07	C2 0.07
C3 0.03	C3 0.03	C3 0.03	C3 0.03	C3 0.03
nC4 0.00	nC4 0.00	nC4 0.00	nC4 0.00	nC4 0.00
iC4 0.00	iC4 0.00	iC4 0.00	iC4 0.00	iC4 0.00
nC5 0.00	nC5 0.00	nC5 0.00	nC5 0.00	nC5 0.00
iC5 0.00	iC5 0.00	iC5 0.00	iC5 0.00	iC5 0.00
C6 0.00	C6 0.00	C6 0.00	C6 0.00	C6 0.00
C7 0.00	C7 0.00	C7 0.00	C7 0.00	C7 0.00
C8 0.00	C8 0.00	C8 0.00	C8 0.00	C8 0.00
C9 0.00	C9 0.00	C9 0.00	C9 0.00	C9 0.00
C10+ 0.00	C10+ 0.00	C10+ 0.00	C10+ 0.00	C10+ 0.00
CO2 0.02	CO2 0.02	CO2 0.02	CO2 0.02	CO2 0.02
Fuel Gas Flowrate 3.6 e³m³/d	Fuel Gas Flowrate 10.0 e³m³/d	Fuel Gas Flowrate 8.6 e³m³/d	Fuel Gas Flowrate 0.0 e³m³/d	Fuel Gas Flowrate 3.6 e³m³/d
CO2 Production 7.4 Tonnes/d	CO2 Production 21.4 Tonnes/d	CO2 Production 18.2 Tonnes/d	CO2 Production 0.0 Tonnes/d	CO2 Production 7.4 Tonnes/d



Additional Opportunities

Cooling System Surveillance

- Ability to detect heat exchanger problems in two stages
 - Addition of temperature readings to detect fouling
 - Addition of flow metering to detect erosion risk

Lubrication System Surveillance

- Ability to detect lubrication system issues
 - Additional lube oil system measurements required



How to Make It Work?



Dashboard Solution

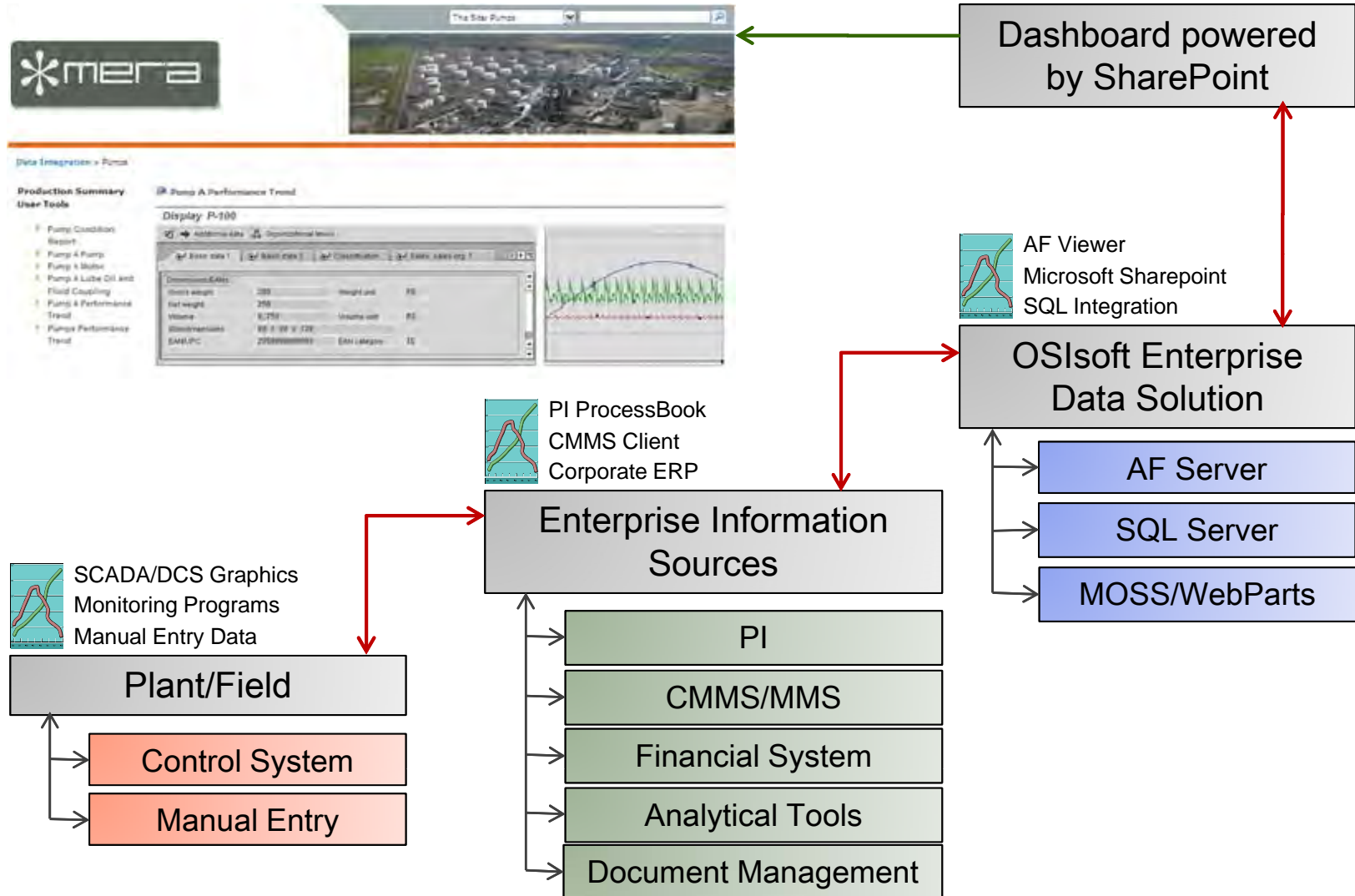



The PRIZE



Typical “Soft” Benefits

- Schedule preventative maintenance & assign resources where they will do the most good
- Identify & track uptime to determine where & why equipment might fail & plan alternatives
- Maintenance data enables reliability modeling which can be used to predict & avert failures
- Full audit trail on equipment performance & maintenance make it possible to collect on warranty related claims
- Data allows equipment performance to be incorporated into the strategic planning process to meet corporate performance targets



Typical Monetary Benefits

- Allows common PM tasks on like equipment to reduce downtime & associated production losses – *Maintworld Magazine* indicates that out of every 100 unplanned failures, 20% can be eliminated with proper daily maintenance
- Allows like equipment performing similar tasks to be compared across the organization to determine best practices
- Allows common failures to be monitored more effectively to support RCAs & proactive corrective actions to be taken on similar equipment on other assets to minimize future downtime & production losses



Combining Data to Create New Information

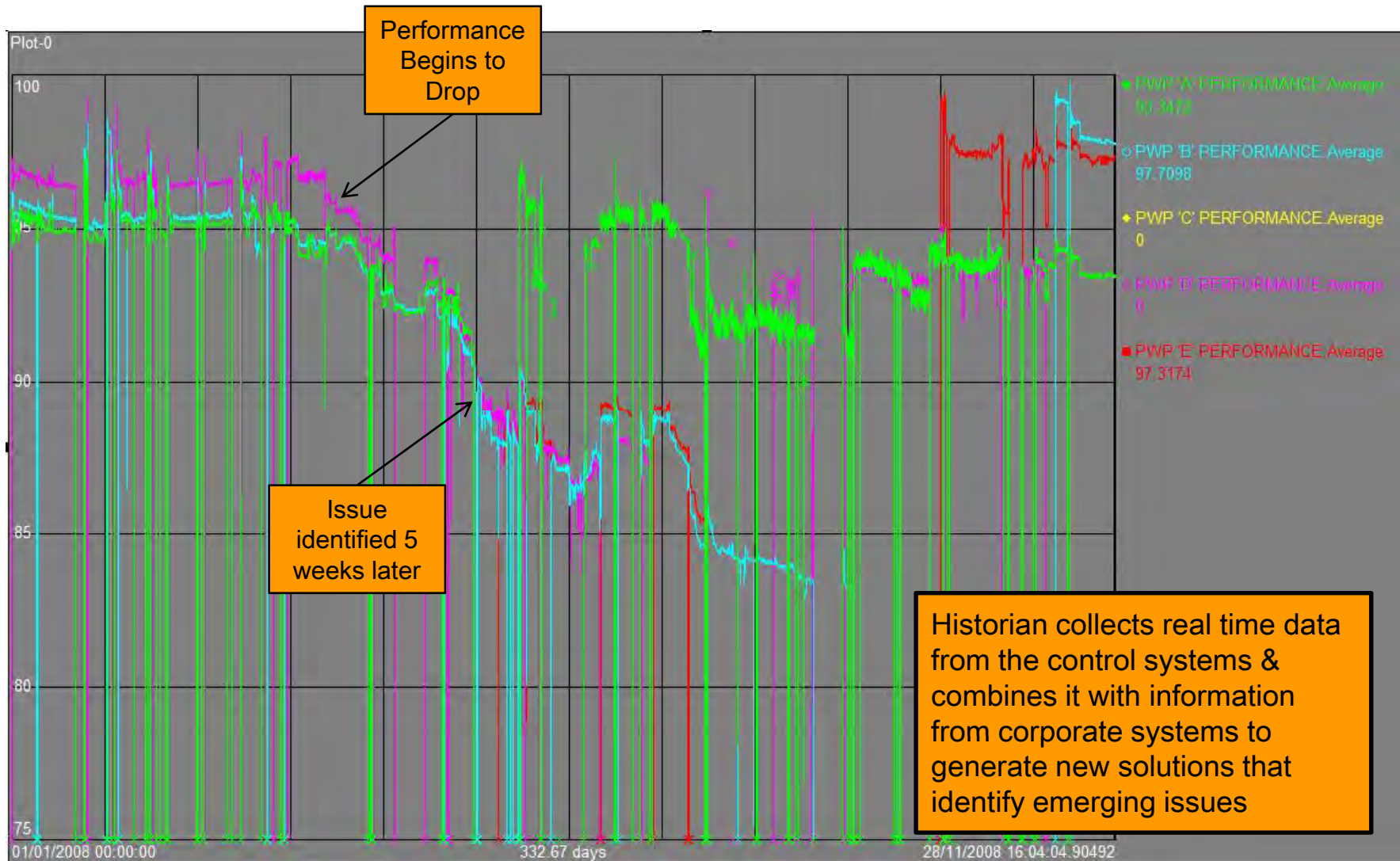



Dashboard – Pump Overview

Site Actions | Welcome System Account

This Site: Pumps



Mera Group of Companies

Compressors | Pumps | Wells



Data Integration > Pumps

Production Summary | Pump A Pump

User Tools

- > Pump Condition Report
- > Pump A Pump
- > Pump A Motor
- > Pump A Lube Oil and Fluid Coupling
- > Pump A Performance Trend

TRANSFER PUMP 'A'

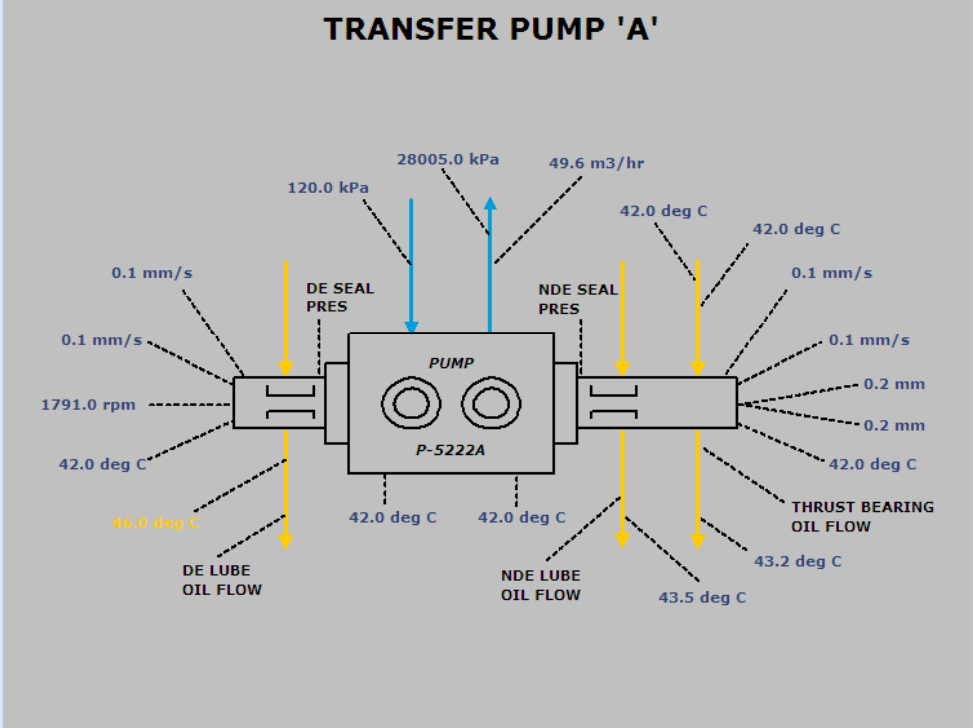

The diagram illustrates the operational parameters for Transfer Pump 'A' (P-5222A). Key data points include:

- DE SEAL PRES:** 120.0 kPa
- PUMP PRESSURE:** 28005.0 kPa
- Flow Rate:** 49.6 m³/hr
- Temperature (Inlet/Outlet):** 42.0 deg C
- Temperature (DE LUBE OIL FLOW):** 46.0 deg C
- Temperature (NDE LUBE OIL FLOW):** 43.5 deg C
- Temperature (THRUST BEARING OIL FLOW):** 43.2 deg C
- Temperature (Internal):** 42.0 deg C
- Speed:** 1791.0 rpm
- Vibration (DE SEAL PRES):** 0.1 mm/s
- Vibration (Internal):** 0.1 mm/s
- Vibration (NDE SEAL PRES):** 0.1 mm/s
- Vibration (THRUST BEARING OIL FLOW):** 0.1 mm/s
- Clearance (Internal):** 0.2 mm
- Clearance (THRUST BEARING OIL FLOW):** 0.2 mm



Questions?